

Valve

Connection sizes A	Height (mm) (to top flat of dome) B	Width (mm) (without fittings) C	Depth (mm) (diameter of dome) D
3/8" (10mm) connection Max Fuel Flow Rate 180ltr/hr at 1.2m head	72	49	47
1/2" (15mm) connection Max Fuel Flow Rate 360ltr/hr at 1.2m head	74	57.4	47

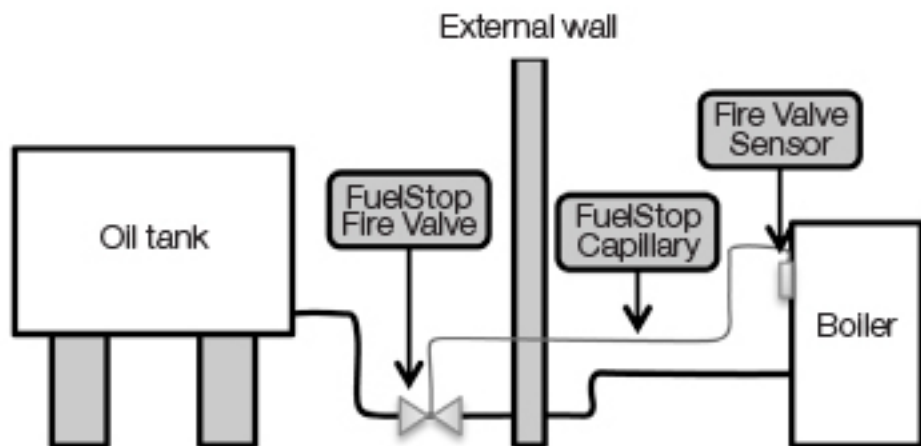

Test in accordance with correct standards.
Fire valve testing kits are available from merchants.